



5qt H-Style Sharps Container

Product Code: 0354-150H

General Description

- Designed for in unsupervised patient areas
- Puncture-resistant , transparent body allows for easy viewing

Material:

High Impact Polypropylene
Country of Origin: China

Product is recyclable

Packing Details

Case:	20 each/case
Packaged:	Each
Case Dimensions:	23.75 x 17.25 x 11.5"
Case Weight:	16 lbs
Cube Dimension:	2.72
Cases per Skid:	24

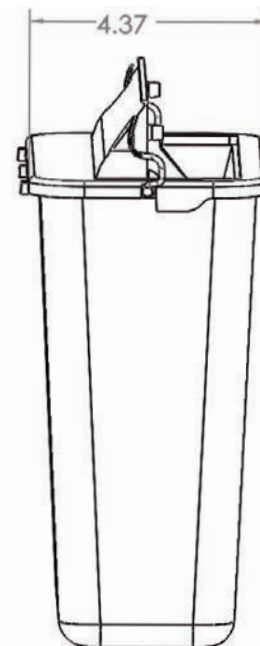
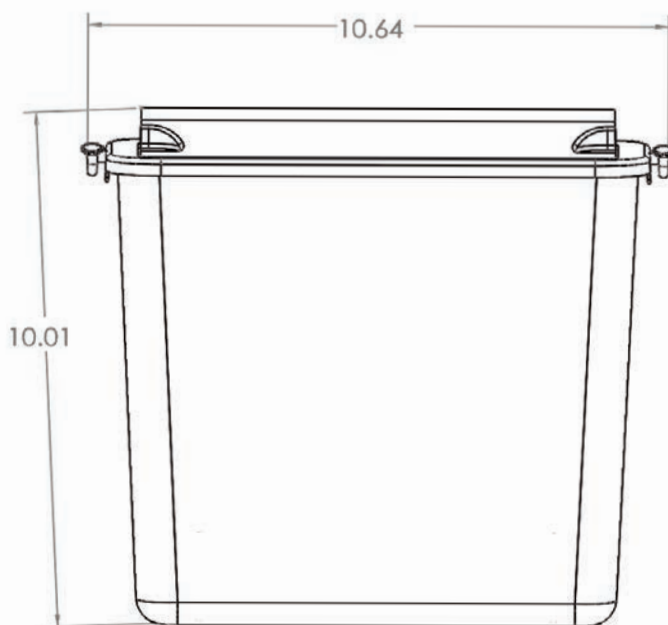

Manufactured by Oak Ridge Products, LLC
FDA Manufacturing Facility Registration
#1419823 & 3006060667

Product dimensions listed are in millimeters

OAK RIDGE PRODUCTS, LLC.
ALL RIGHTS RESERVED

US:888-650-7444 INT'L:001-815-363-4700
WWW.OAKRIDGEPRODUCTS.COM

REV. 1/10/14